

The Focus



A Publication for ANSYS Users

Contents

Feature Articles

- [Fixing Bad CAD with CADfix](#)
- [Automatic Geometry Healer](#)
- [PADT Forms SWAU Just For You!](#)

On the Web

- [The SWAU Resource Center](#)

Resources

- [PADT Support: How can we help?](#)
- [Upcoming Training at PADT](#)
- [About *The Focus*](#)
 - *The Focus* Library
 - Contributor Information
 - Subscribe / Unsubscribe
 - Legal Disclaimer

CADfix[®]

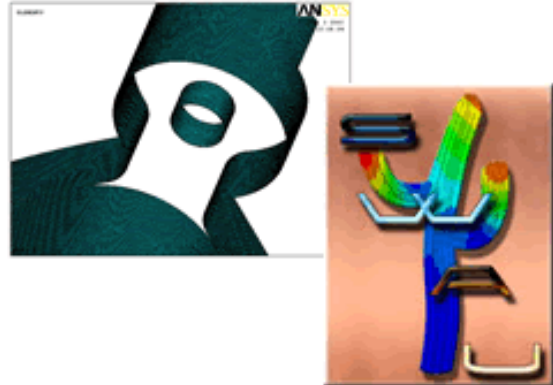

ANSYS[®]
Support Distributor

© 2002, by Phoenix Analysis & Design Technologies, Inc. All rights reserved.

The Focus



A Publication for ANSYS Users

Fixing Bad CAD with CADfix

by [Eric Miller](#), PADT Inc.



When ANSYS users are polled on which part of their job is the most painful, a common answer is Getting a good volume in ANSYS from my CAD geometry. We have all had to struggle with small slivers, areas that do not share edges or the dreaded bounding curve not in tolerance messages. Over the past 8 years or so, a group of developers in England has been working on a tool that solves many of these problems. This tool can successfully transfer CAD geometry into ANSYS around 95 percent of the time, even when your CAD system is CATIA.

CADfix, from ITI-TranscenData, is a tool purposely built for Finite Element analysts to clean up their geometry. The program has the capability of reading a huge variety of formats, including:

- IGES
- STEP
- Parasolid
- ACIS
- CATIA
- CADD5
- STL
- VDA-FS

The Focus



A Publication for ANSYS Users

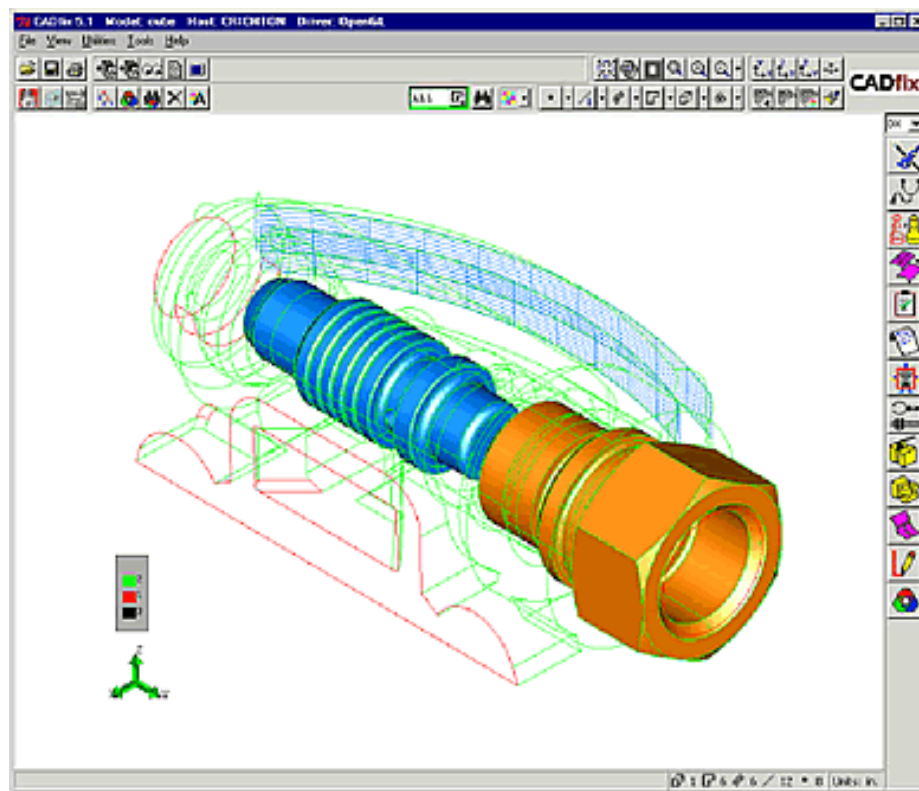

Figure 1. CADfix 5.0 user interface.

The user interacts through a pretty intuitive Graphical User Interface that includes a number of automation tools, and includes a Wizard that automatically does most of the work for you. The nice thing about the interface is that even though the automatic tools work most of the time, they still let you get in there and tweak any of the tools by hand. This is particularly useful if you have a tough and nasty model that needs a human brain to fix. Figure 1 shows a snapshot of the GUI.

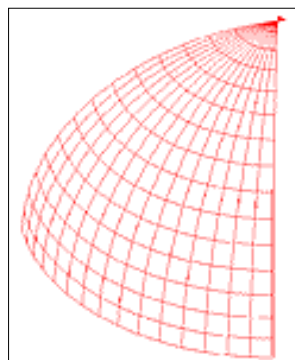

Figure 2. Surface that crosses over on itself: self-intersecting.

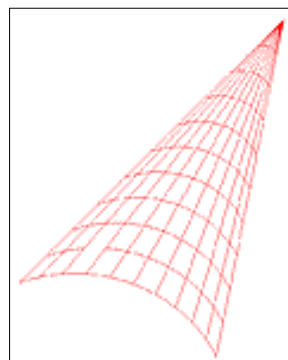

Figure 3. Surface with degenerate edge.

The bulk of the program is dedicated to repairing common problems in CAD files. Figures 2 through 7 show some of the common problems that CADfix can repair. In addition, there are tools to defeature geometry that include merging surfaces, combining small edges into one edge, and collapsing small features. The toolbox is rounded out with some geometry creation and slicing tools.

The Focus



A Publication for ANSYS Users

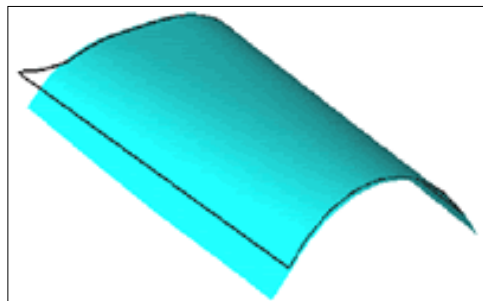

Figure 4. Bounding curve does not sit on surface.

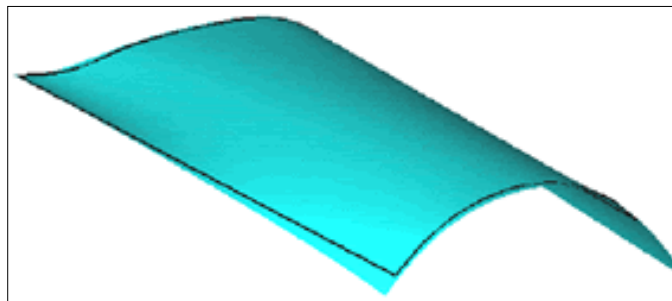

Figure 5. Bounding curve does not follow edge of surface.

All of these tools are made useful by the diagnostic features of the program. As you work with the model, problems are shown to the user through the use of colors on points, edges, or surfaces to let you know where things are not lining up and what is keeping your geometry from becoming a well behaved solid.

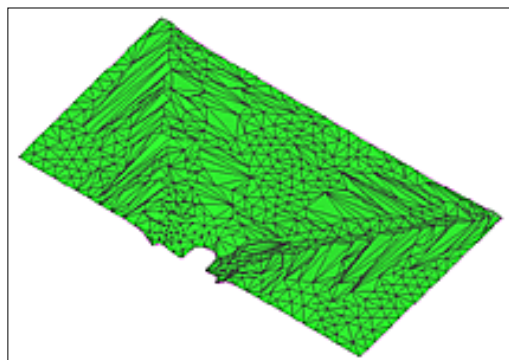

Figure 6. Surface parameterization is just plain wrong.

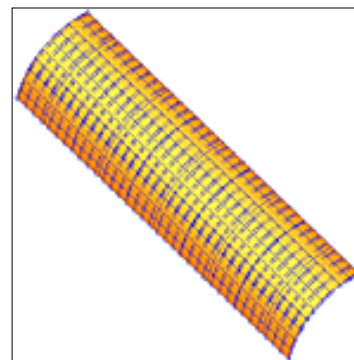

Figure 7. Overlapping surfaces.

Once all of your repairs are done, you can export to a large number of formats, including an ANSYS *.anf file:

- IGES
- CADD55
- STL
- ANSYS
- STEP
- Parasolid
- VDA-FS
- FEMGV
- ACIS
- SCO3

If you spend any amount of time struggling in either ANSYS or your CAD system trying to fix your geometry so you can get a volume that you can mesh, then you should definitely consider looking at CADfix. It can literally save hours of time and will let you focus on doing analysis not on geometry repair.

PADT has used this tool off and on for around 5 years, and we have found it to be invaluable. Several of our customers use CATIA, and using this tool is the only way we have found that we can efficiently conduct analysis on geometry that is defined in V4. In addition, it seems like Pro/Engineer sometimes makes wacky geometry that ANSYS just won't handle, and CADfix always comes through with a simpler, more robust model. It also provides a fix for our number one complaint about ANSYS pre-processing: slivers. A lot of small and thin surface will be taken out with the automatic repair capabilities in CADfix, but for those real hard to get surfaces, you can use the merge surface function to make them go away.

For more information, please contact [PADT](#) or visit the [CADfix web site](#).

The Focus



A Publication for ANSYS Users

Automatic Geometry Healer

by [Rod Scholl](#), PADT Inc.

Healing Geometry is often the most difficult part of the FEA process. Surveys of our customers indicate this is the number one area for process improvement.

The major options for dealing with imported geometry with poor definition is as follows:

- A. Fix the geometry in the originating CAD package (the preferred solution)
- B. Fix the geometry in ANSYS using solid modeling
- C. Mesh the geometry external to ANSYS (such as ICEM or the Workbench environment) and import the mesh only
- D. Use one of many products to heal, reinterpret, convert the geometry definition

My take on the options:

- A. Being an FEA guy, and receiving the bulk of my geometry from a designer, I naturally vote for Option A! And put a fire under it, will ya?
- B. It is easy to spend a 40 hours a week, merging, coons-patching, bottom-up repairing a model with poor geometry definition (Option B above) and still have trouble meshing let alone performing Booleans, etc.
- C. Meshing external to ANSYS has disadvantages with ease of applying BC s, lack of automation, among other problems unique to different packages.
- D. Geometry Repair: There are a few products in this area but we are going to focus on the **ANSYS AGH** module.

CADfix has been a big name in geometry healing for some time, including the discontinued product *CADfix for ANSYS*. But the overall functionality still exists for ANSYS users through the ANSYS Automatic Geometry Healing (AGH) Module available for purchase. The AGH is essentially the CADfix for ANSYS Wizard automated and run as a batch command that iterates to find and repair the problem topology.

I had tried this out only once when writing the [previous article](#) on AGH, and it was a considerable wait for little noticeable change in my bad geometry. However, this time around I tried it on poor geometry, and with a single command fixed an otherwise unworkable model. This model had 2000+ areas, rendering it impossible to fix by hand especially given over 1200 areas failing the first AMESH, ALL command. Looking at the model, it was obviously created poorly and the designer who created it should be chained to his desk until it is acceptable. But back in the real world, that is often not an option.

The Focus



A Publication for ANSYS Users

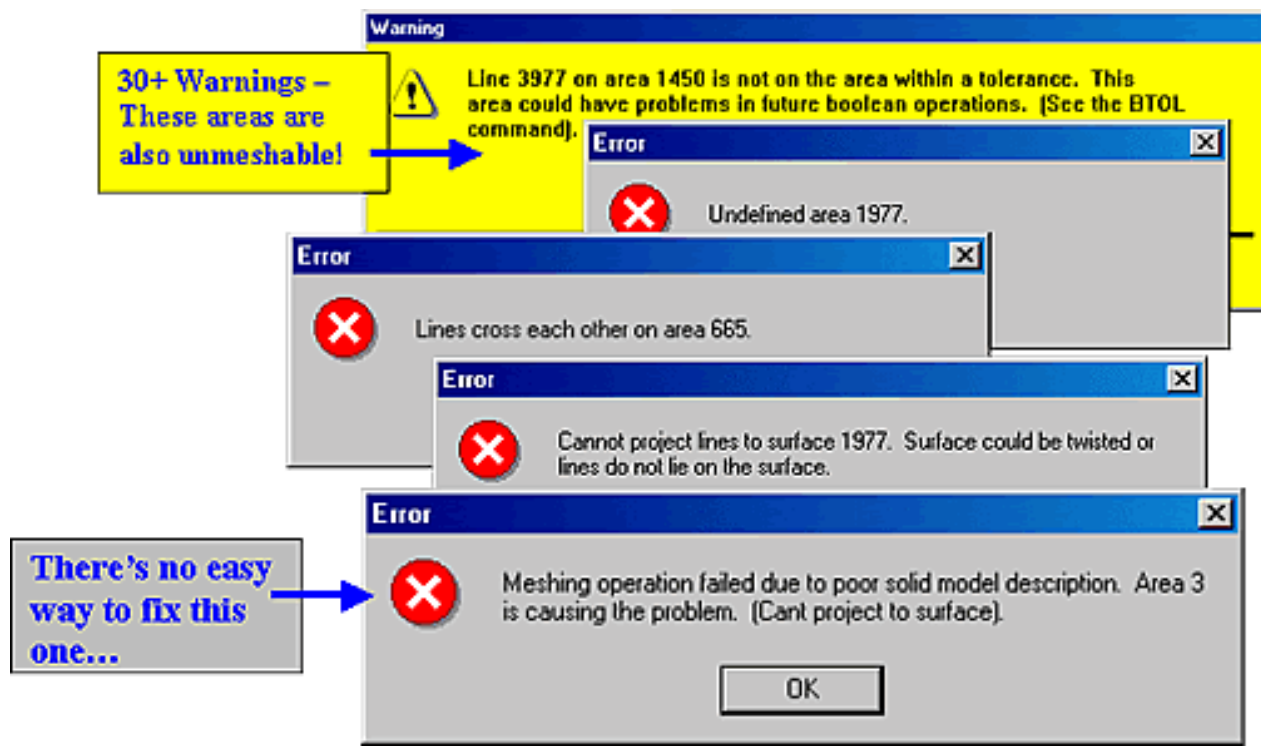

Without ~HEAL, the poorly defined geometry file yields a series of informative error messages that point out the problem during Pro/E Connection product import (IGES transfer was even worse).

Trying to Mesh the Imported Geometry

No Heal + Pro/E Connection Import: Some areas, could not be meshed despite many advanced approaches. Perhaps eventually, I would have found a magic LESIZE combination....

The Focus



A Publication for ANSYS Users

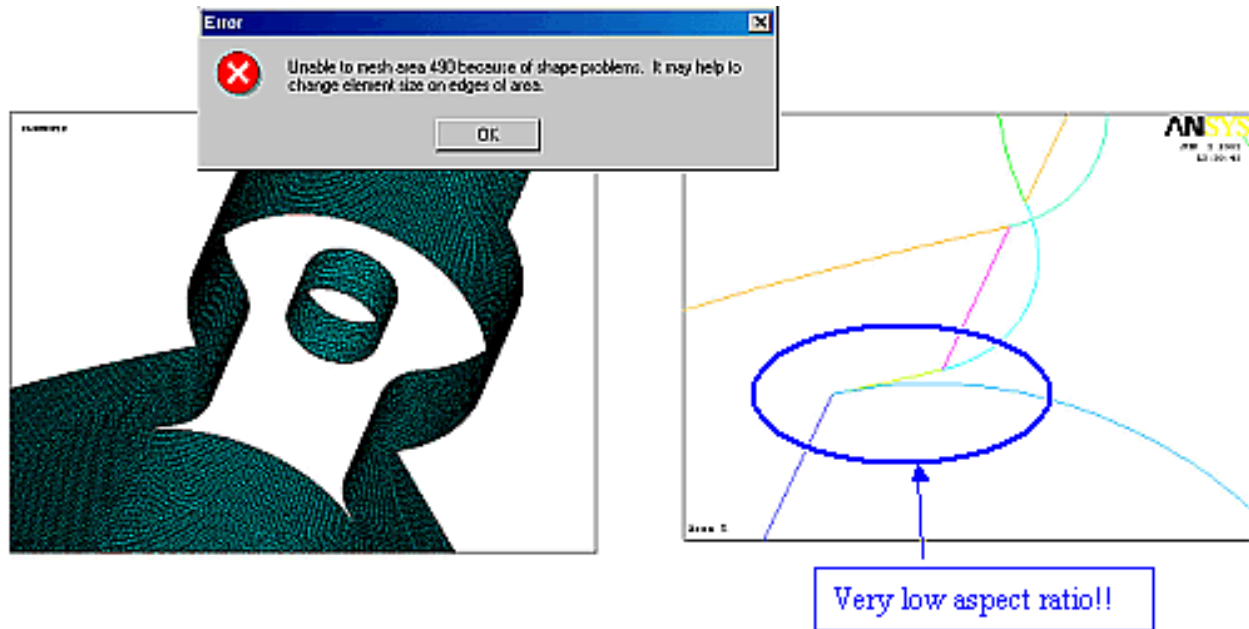

Pro/E Connection + ~HEAL (AGH) Import: All the areas were meshable with reasonable element size and shape. Even the sliver areas!

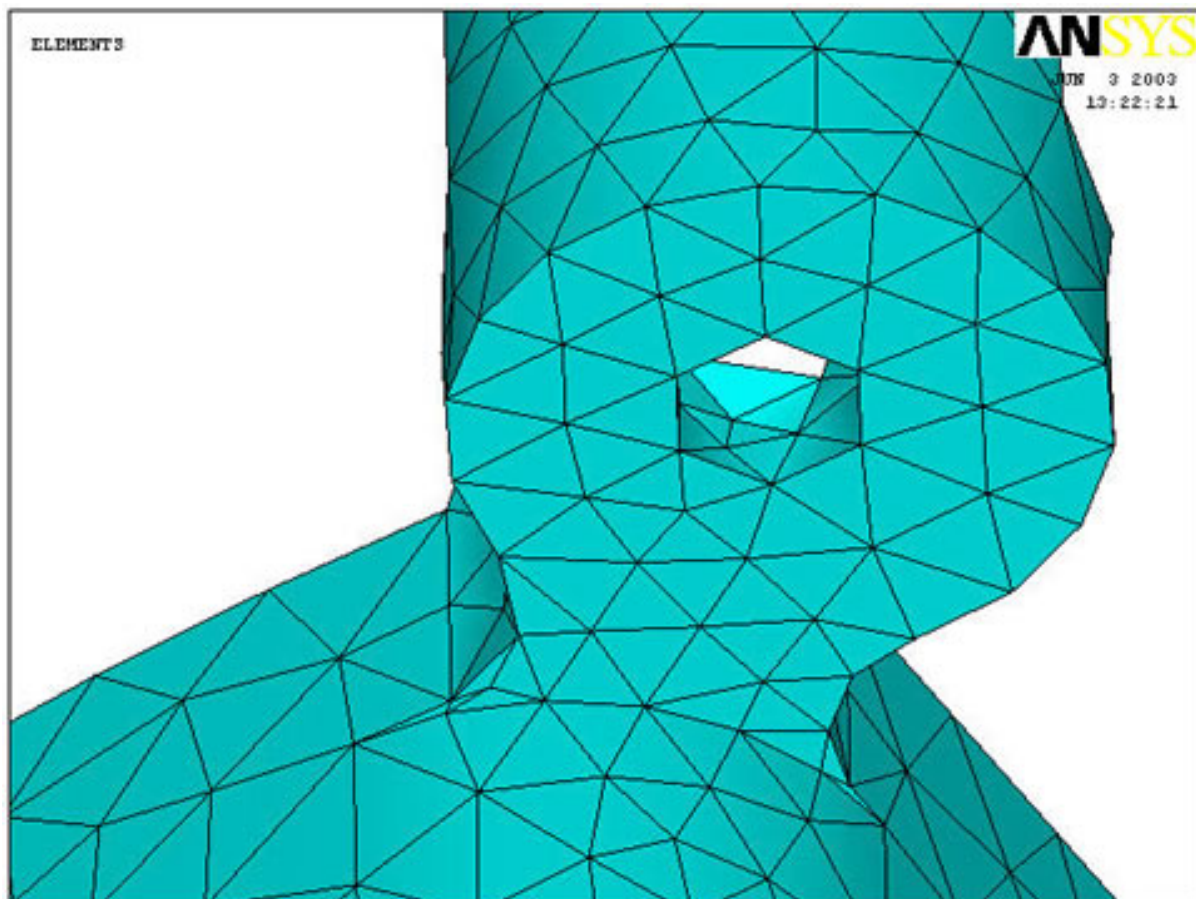

Not the best mesh, I know. But this was a large model, and this region is removed from the area of interest.

The Focus



A Publication for ANSYS Users

A Couple of Side Notes

The importation into ANSYS Workbench using the connection products gives superior performance over ANSYS Classic. Look for more information on ANSYS Workbench in future issues of *The Focus*.

Also, when meshing in ANSYS Classic, take advantage of the new and powerful SPLOT and MOPT,AORDER,ON commands, which allow you to view the native untrimmed surface definitions, and also to specify meshing of areas in order of increasing surface area. This allows you to automatically mesh the small areas first, which can greatly improve the meshability/quality of elements.

A Little More Help

The usage instructions are trivial under the ~HEAL command (or GUI under File > Import > Heal) as described [previously](#). Plus, it works in tandem with Native geometry reading licenses you may have!

Often, with a single healing operation, the AGH module pays for itself. I suspect that the degree of success depends on the topology of your parts, the original modeling package, the methods of the particular designer, etc. Perhaps you may want to collect a couple of historical problem files and submit them to your [ASD](#) to evaluate as test cases. If you're in the Arizona, New Mexico, El Paso area, that would be [me](#)!

The Focus



A Publication for ANSYS Users

PADT Forms SWAU Just For You!

PADT is pleased to announce the formation of a User Group organization for ANSYS users and all others interested in ANSYS who are located in the Southwest (Arizona, New Mexico, and El Paso). This new group is called the Southwest ANSYS Users group, or SWAU (swah-oo) for short. The goal of the organization is to:

provide a sense of community for ANSYS users in the Southwestern U.S., to serve as a means of communication about ANSYS, and to provide technical and peer resources to those interested in becoming ANSYS users.

PADT's monthly technical seminars will move under this umbrella, and a new newsletter, the SWAU Report, will serve as the official communication tool of the organization. Additional information will always be available at the [SWAU Center](#) on PADT's web site. PADT will be planning at least one large event (the SWAU Soirée) with the ANSYS Inc. developers and other movers & shakers, in addition to several smaller, more social ones. We are also actively looking for other ideas from the user community.

Membership is absolutely free! If you receive a newsletter by e-mail, you are already a member. All others can subscribe by visiting our e-Publications [subscriptions](#) center, entering your e-mail address, and checking the box next to The SWAU Report. Questions and comments may be sent to swau@padtinc.com.



The Focus



A Publication for ANSYS Users

About *The Focus*

The Focus is a periodic electronic publication published by PADT, aimed at the general ANSYS user. The goal of the feature articles is to inform users of the capabilities ANSYS offers and to provide useful tips and hints on using these products more effectively. *The Focus* may be freely redistributed in its entirety. For administrative questions, please contact [Rod Scholl](#) at PADT.

The Focus Library

All past issues of *The Focus* are maintained in an online [library](#), which can be searched in a variety of different ways.

Contributor Information

Please don't hesitate to send in a contribution! Articles and information helpful to ANSYS users are very much welcomed and appreciated. We encourage you to send your contributions via e-mail to [Rod Scholl](#).

Subscribe / Unsubscribe

To subscribe to or unsubscribe from *The Focus*, please visit the PADT e-Publication [subscriptions](#) management page.

Legal Disclaimer

Phoenix Analysis and Design Technologies (PADT) makes no representations about the suitability of the information contained in these documents and related graphics for any purpose. All such document and related graphics are provided as is without warranty of any kind and are subject to change without notice. The entire risk arising out of their use remains with the recipient. In no event, including inaccurate information, shall PADT be liable for any direct, consequential, incidental, special, punitive or other damages whatsoever (including without limitation, damages for loss of business information), even if PADT has been advised of the possibility of such damages.

The views expressed in *The Focus* are solely those of PADT and are not necessarily those of ANSYS, Inc.